

Diaphragm type differential pressure gauge Model D104

Max. Static pressure 100 bar

Nominal size: 100 mm (4"), 150 mm (6")

ASME B40.100 / EN 837-1 / IS-3624

Accuracy: Class 1,6 (1.6%) optional Class 1 (1%)

Features

- Stainless steel case and wetted parts
- Max static pressure 100 kg/cm²
- High corrosive resistance
- Dry or liquid filled
- IP65

Ranges

0 ... 40 in H₂O up to 0 ... 350 psi

0 ... 1000 mmWC up to 0 ... 25 bar & kg/cm²

0 ... 10 kPa up to 0 ... 2500 kPa



Applications

Chemical and petrochemical industry

Machine and apparatus construction

Food and beverage industry

Pulp and paper industry

Technical specification	D104	
Dial size in mm	100	150
Construction	Cylindrical case	
Measuring principle	Single diaphragms	
Static Pressure	100 bar both side	
Pressure range	1000 1600 2500 4000 mmWC	
Max static pressure	0,6 1 1.6 2.5 4 6 10 16 25 kg/cm ² (or bar)	
Overload capability	100 bar	
Pressure type	200% of full scale	
Process connection	Differential	
Connection location	1/4" NPT (F), 1/4" NPT (M), 1/2" NPT (M), 1/4" BSP (M), 1/2" BSP (M), others on request	
Material	Lower	
Pressure element	Stainless steel 316L for ranges ≤2.5 bar Duratherm for ranges > 2.5 bar	
Measuring diaphragm	Stainless steel 316L	
Case/bayonet ring	Stainless steel 304, optional 316	
Window	Laminated safety glass	
Dial	Aluminum, black markings on white background	
Pointer	Micro Pointer Aluminum, black	
Accuracy	Class 1,6 (1,6 % F.S.), optional Class 1 (1 % F.S.)	
Permissible	±2% at maximum static pressure	
Zero shift	-40 ... 60 °C (-40 ... 140 °F)	
Ambient temperature	Max. 100 °C (212 °F)	
Medium temperature	-40 ... 65 °C (-40 ... 150 °F)	
Storage temperature	Max. 0,6 % / 10 K	
Effect		
Protection according EN 60 529/IEC 529	IP65	
Filling liquids	Glycerin, silicone, others on request	
Mounting	Direct, optional 2" pipe mounting	
Weight dry/filled in kg	2.2 dry / 2.5 filled	2.4 dry / 3.1 filled
Accessories, options	3 or 5 way remote or direct mounted manifolds, valves, NACE	

General dimensions in mm

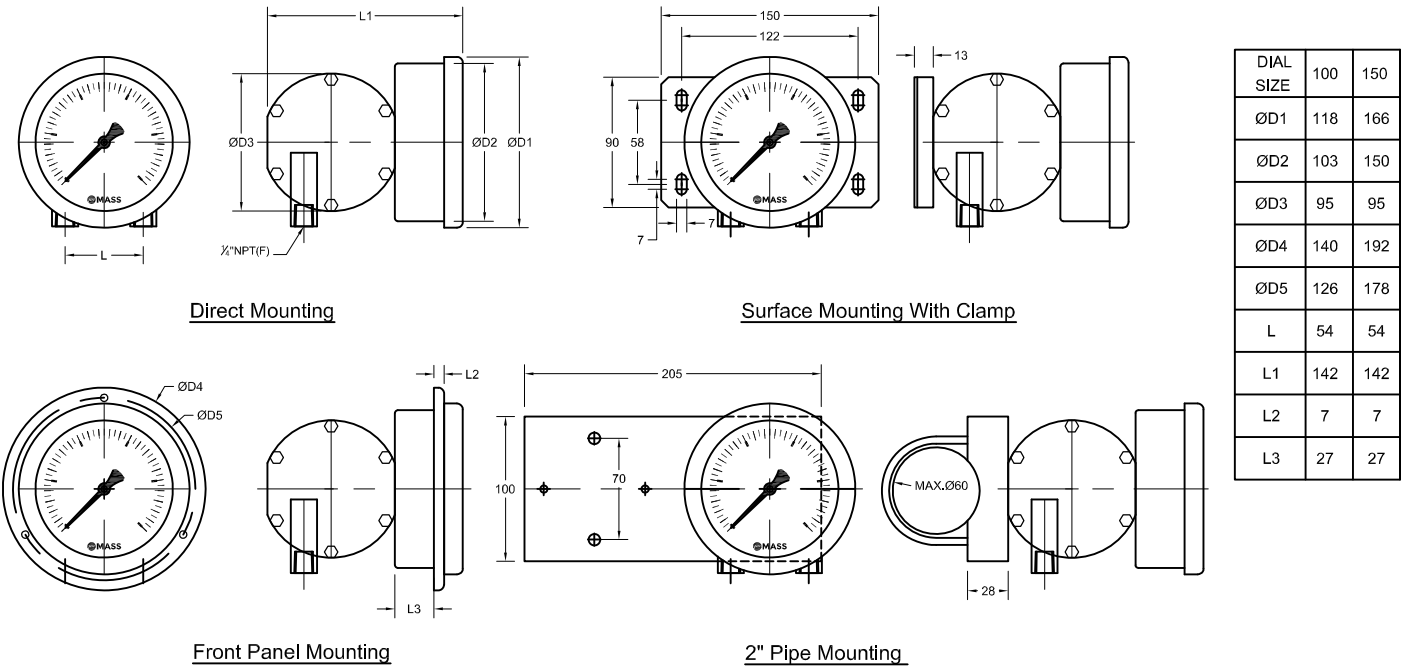

Order information

Size	System material	Execution	Process connection	Connection orientation	Range	Engineering unit	Filling/case/contacts	Options
(100) 100 mm	(S) Pressure chamber 316L & Diaphragm ≤2.5 bar 316L > 2.5 bar Duratherm	(L) IP65	(02) 1/4" NPT (M)	(L) Lower	0/1000 ²⁾ 0/1600 ²⁾ 0/2500 0/4000	mmWC	(=) Standard no filling	(NH) Tagging wired (CS) Dual scale (DA) Dial marking (AN) Calibration 1% ¹⁾ (FX) Front panel (FW) Surface plate (TM) 2" pipe mounting bracket
(150) 150 mm			(04) 1/2" NPT (M)					
						Equivalent ranges in kPa, MPa, psi, bar and others units available		
						compound ranges on request		

1) Accuracy 1% is excluding Hysteresis 2) Dial arc shall be 180°

Order example

Size	Type	System material	Execution	Process connection	Connection orientation	Range	Engineering unit	Filling/case/contacts	Option
100	D104	S	L	02T	L	0/1	KG/CM2	=	NH